

WINDRUSH DOUBLE BEAM PUMPS

Basil Harley and R.T. Holmes

During our study of the waterpower generated by the River Windrush in the 19th century when it was used for such diverse purposes as corn grinding, paper, blanket and manure making, we found that substantial investments had been made into the re-distribution of the water itself. We had taken as our geographical terms of reference the catchment area of the river and its tributaries. However, it had not been immediately obvious to us that much of the rainfall which found its way into the river had to be pumped back to the tops of many of the hills to serve village communities, isolated farmsteads and the varied requirements of the large estates. A wide range of machinery had been developed to harness wind, water and manual power for this purpose and there are still many examples of the earlier technology to be found in the Cotswolds, sometimes still at work but often much deteriorated under banks and hedges or in derelict pumping houses.

The preferred sources of potable water were the many springs and wells rather than the river itself which could often be polluted by the processes carried out in the main mills. Often the spring water could be piped to the consumers with little difficulty but this was not possible for communities on higher ground. Where the water table was not too deep the classical village pump served small communities. These were often made locally and for over a century Burford was the home of skilled water engineers. In the early 1840s a William Hemming set up business there as an "Engineer and Ironmonger, Pumps and Water works of every description". A manuscript book recording some 45 of his contracts shows that he provided hardware and expertise over a large area of Oxfordshire and Gloucestershire.(1) He had customers in places as diverse as Northleach, Middle Aston, Slaughter, Notgrove, Enstone, Sevenhampton and Bibury. In a description of a typical installation in 1859 he stated -

"I, William Hemming, Engineer in Burford in the County of Oxford do hereby agree to find and fix a water engine for Mr H. L. Gaskill of Kiddington comprising an eight foot diameter overshot waterwheel, fourteen inches wide with cranks and ironwork to work four 1 1/2" forcing pumps with brass plungers and packing boxes and brass valves and union joints and lead pipe to connect with the main pipe to the house for the sum of 50".

The Gaskills owned Kiddington Hall until the late 1930s and the pump house and Hemming's waterwheel still exists (Map Ref SP 410 228) but the original machinery has been replaced by two later horizontal pumps.

It was usual for the erection of an engine house and the stonework to be either provided by the customer or sub-contracted. John East, a local stonemason, was frequently used for this and at some time in the 1860s he or his son Charles took over Hemmings' business. Charles was born in 1837 and he died in 1934.(2) During his life the works expanded to an iron foundry, a machine shop and erecting and testing shop for the waterwheels. (FIG 1) The foundry provided a range of cast iron hand pumps and a good example is still extant on Little Barrington village green. It was purchased in October 1895 by the new Parish Council for 16

10s. 9d. Including installation. It remained in use until the early 1950s to supplement the local estate supply, before all was taken over by Thames Water.

Charles East's expertise as an hydraulic engineer developed and in 1888 he and his son Cilo took out a patent (No 1059) for "Improvements to Taps, Valves, Hydrants and the like". They described themselves Water Works Engineers of Burford, Oxon. The object of the invention was to enable various kinds of valves to be removed for examination and repairs without "cutting off the pressure", as they put it. A key element in the patent was the use of a ball as part of the sealing process. This was to be "preferably formed of india rubber with a wood core and will float in water". There is evidence that the principle was applied to the valves in force pumps as well as taps and other valves. Since the supplementary ball needed to float it necessitated the pumps being mounted vertically. It is not clear when the characteristic Windrush wooden beams were first used to operate the vertical pumps but a major advantage was that the pump rod worked in virtually a straight line and that the stroke could be varied by positioning it at various distances from the beam pivot. I am indebted to Mr Alexander Hollis, a descendant of the East family, for calling my attention to this and to the patent.

One of these installations is still at work on the Barrington Park Estate; it is known as the Taynton pump and probably dates from the middle of the 19th century. (FIG 4) It is housed in a stone building at the bottom of a steep-sided combe, difficult of access, and on private land belonging to the estate. Map Ref SP 233160. The roof was re-built and the mechanism restored to working order two or three years ago by Green and Carter, hydraulic ram makers of Ashbrittle, Somerset. Power comes from what was referred to as Combe Brook on the 1886 OS 6" map but which has been called Hazleford Brook on 1950s and later maps. It runs into the River Windrush in Taynton village.

The pump house contains a breast-shot iron waterwheel with six spokes, 10 feet in diameter by 3 feet wide. The water to the wheel is controlled by a reduction gear operated penstock which is normally left fully open. It is visited by estate staff about once a fortnight for inspection and oiling. On our visit the wheel speed was 10 rpm. The clean water supply comes from one of numerous springs and is piped into the pump house to a small open-topped reservoir of about ten gallons capacity with an overflow. Two vertical pumps of some 1 foot stroke by 2 inches diameter are fed from the reservoir and distribute the water via separate systems to various cattle troughs and other outlets on the estate. A pair of cast iron air bottles each have lettering cast on "East and Son Burford", who were responsible for the original installation, including the pumps which they manufactured.

The wheel has an iron shaft and on each end is a disc crank of 10 inches stroke. The drive from the cranks to the pumps is via overhead beams of 6 inch by 3 inch timber which are hinged on the upstream wall of the pump house. Each beam is moved by a connecting rod from the disc crank. A further connecting rod about 18 inches further along the beam away from the hinge drives the pump plunger giving a stroke of about 12 inches. The outer ends of the beams slide up and down between wooden guides fixed to vertical timbers in the house. It is this design of drive, which has not been identified elsewhere, which is thought to be special to the Burford company and used extensively in the Windrush valley.

Elsewhere on the Barrington Park estate are the remains of an installation which supplied water to the House, the estate and a number of adjacent villages until the 1950s. It is on the River Windrush in Waterloo Copse, Map Ref SP 203 133. An undershot wheel 10 feet diameter by 4 feet wide has a disc crank of 18 inch stroke on each end of the wheel shaft. The feed channel and the tailrace are about 2 feet 6 inches wide, narrower than the wheel, and only a few yards upstream and downstream of the wheelhouse. It seems possible that the wheel was brought in second hand from elsewhere. The pump house is in a derelict condition, the walls only 3 feet high, but there are remains of charming wooden gothic doors. No machinery other than the wheel remains. It is remembered locally as being of the double beam type when working.

Similar pumps have been found elsewhere in the Windrush catchment area and there are others, notably in Heythrop Park, Oxfordshire, also designed or installed by Charles East. On an un-named tributary to Sherborne brook, Sherborne village, are the remains of a pump which supplied water to Sherborne House and the estate. Map Reference SP 173143. It is inside the National Trust park wall a few hundred yards from the lower entrance opposite the school. In deeply overgrown woodland the building has collapsed and no machinery remains. It is also remembered locally(3) as being of the double beam type and continued working until the 1960s.

At Asthall, downstream of Burford, a single beam pump installed by East was working until the 1970s but has now been removed. The wheel still exists in a local farm. (FIG 3) A mile or so away at Signet Map Ref SP 246 104 are the remains of another of East's twin pump installations still showing the wheel and beams, though the pumps have vanished. The village of Kinton was supplied with water from a similar installation. The remains of this are still extant in a stone pump house on a private estate and there are traces of the watercourse. Map Reference SP 098 265. At Steeple Barton in Oxfordshire was another, a single pump similar to the Asthall one, made and installed by East's. This, Map Reference SP 455 236 has now been demolished. Another one in the Kinton area, very much smaller, is still lurking under a hedge just off the road Map Reference SP 099 264 There are sufficient remains here to show that the two wooden beams were fastened to the pump house wall with gate hinges. It is known that the East family, probably Charles, installed pumps in this area.

Others so far identified from maps, mainly the 1888 OS 6" to mile, and later ones, as having been designed or installed by the Burford firm on the River Windrush and elsewhere within some twenty five miles of the town from the middle of the 19th century are listed here. In a number of cases no remains have been traced or there is no evidence as to what kind of pumps were used.

A wheel driven pump to the west of the village of Naunton supplied water to Naunton Inn. Map reference SP 108 235. Nothing remains.

Pump on Windrush upstream of Bourton on the Water. Nothing traced. Map Reference SP 162 209. Another is marked on the Aston reach on the 1922 25" map

Pump on Sherborne Brook, presumably for the Sherborne Estate. Map Ref SP 177 147

Heythrop Park. Four pump houses on the estate, two restorable, two derelict. Map References SP 273 280, SP 360 265, SP 368 270 and SP 361 265

Upton. Map Ref SP 231 126 Remains of small wheel, about 4 feet diam half buried in It was almost certainly installed by East and Son, as a replacement for manual pumps supplied by Hemming in 1858.

These pumps are somewhat neglected examples of minor technology designed by ingenious country engineers. On farms and agricultural estates they are frequently housed in prominent stone pump houses. However, in the larger establishments, such as Heythrop Park, some care was taken to conceal them from view from the gardens. This makes their discovery even more of an adventure. The provision of more abundant water supplies was done by more powerful waterwheels, mostly undershot or breastshot on the River Windrush or its tributaries, driving either single or triple throw force pumps often lifting from deep wells alongside. The water supply to Burford itself was pumped by a waterwheel until the 1960s, indeed a new wheel (still extant but not working) was made in 1957.(4) Cokethorpe Park has an 18th century water pump housed in a folly called the Fish House which was supplying the estate until the last war. The wooden wheel, 9 feet diameter by 4 feet wide, still remains though the pump house has been converted to a dwelling.(5) Another undershot wheel, 10 feet diameter by 3 feet wide, is still working in Donnington Brewery pumping the 'liquor' for beer making.

References

- 1) William Hemming's work book kindly loaned by Mr Alexander Hollis.
- 2) Mary Sturge Gretton Burford Past and Present 1944.
- 3) Mr Lesley Hayward of Sherborne who played there as a boy.
- 4) Private communication by Mr Adam J. Wilson Consulting engineer, 1985.
The Fish House, Cokethorpe Park. An unpublished monograph by Mr J. Kenneth Major 1983.

Note: Five colour prints relating to this article are held in the Gloucestershire Collection at Gloucester City Library, Ref J 13. 27.

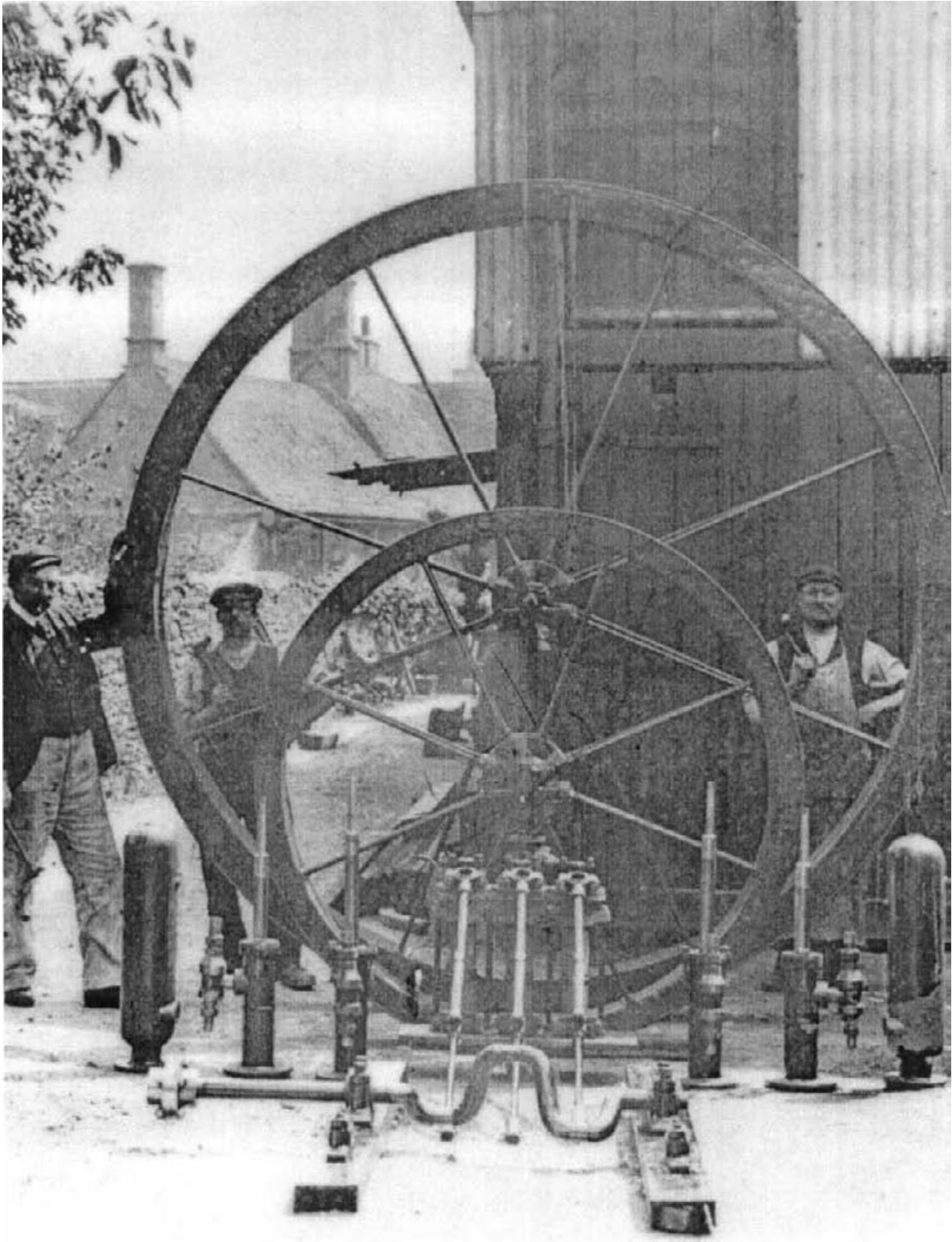

Figure 1 The East Works in Burford. c1890. Charles East is possibly the man on the extreme left.

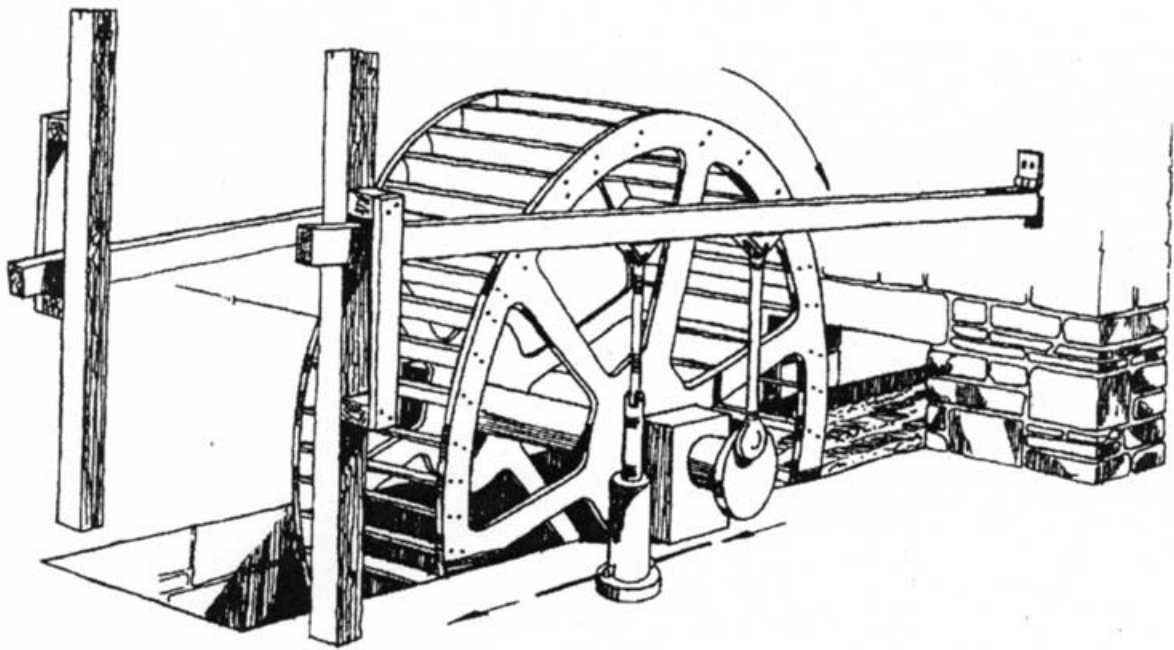

Figure 2. Windrush double beam pump. East and Co's pump in Barrington Park. Restored and running.

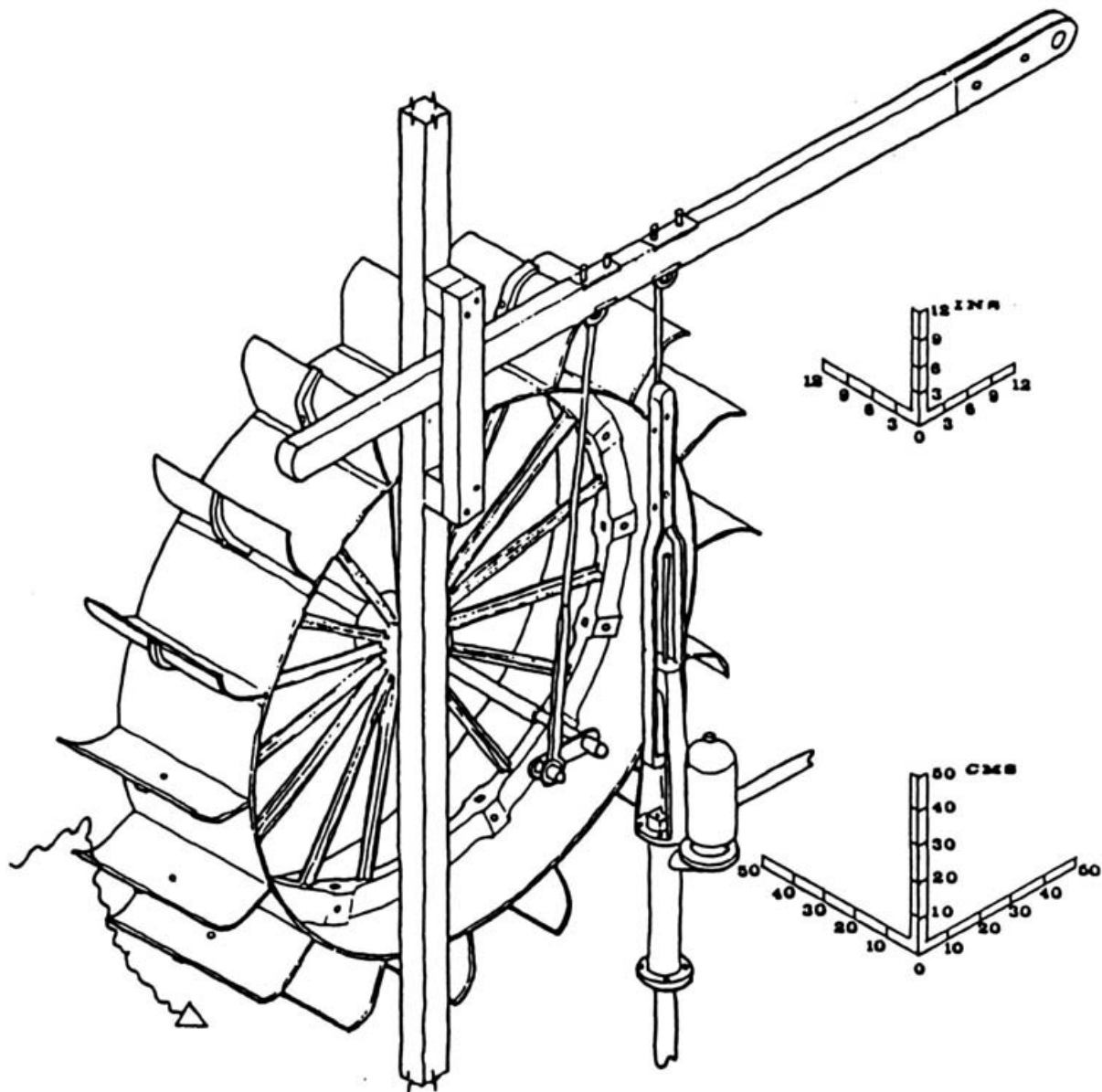

Figure 3 A single beam pump installed by C East and Co. and working to pump water for the Asthall Estate until the 1970s. (Drawing courtesy of Mr J. Kenneth Major).